

**DH2**  
High production,  
excellent separation,  
minimum maintenance

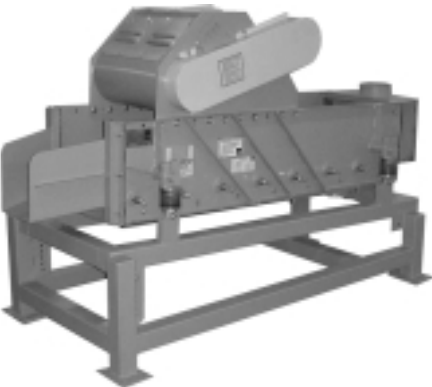

**VIBROSET**  
Adjustable angle,  
speed and stroke



**HORIZONTAL**  
Low profile design with  
excellent throughput for solid/solid  
or liquid/solid separation

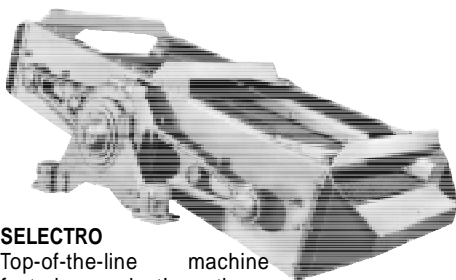

**SELECTRO**  
Top-of-the-line machine  
featuring selective throw  
and adjustable operation tilt

## Did you know...

...that 13 of the 25 leading  
U.S. Crushed Stone Producers depend  
on SMICO Vibratory Screening  
Equipment.\*

\*Source: United States Geological Survey's Top Producers of 2000, AGGMAN Magazine,  
May 2002

For dependable performance and durability these  
companies count on Smico Vibratory Screening  
Equipment.

- Martin Marietta Aggregates
- Hanson Building Materials
- Hanson Aggregates
- Lafarge Corporation
- Rinker Materials Corporation
- Cemex, Inc.
- Florida Rock Industries, Inc.
- Ashland Oil, Inc. / APAC, Inc.
- Blue Circle America, Inc.  
(acquired by Lafarge Corporation)
- Meridian Aggregates Company  
(acquired by Martin Marietta)
- Mathy Construction Company
- RMC Pacific Materials
- The Dolese Brothers Co.

Don't you think it's time that you  
get to know SMICO?



**SMICO Manufacturing Company, LLC**

500 North MacArthur Boulevard  
Oklahoma City, OK 73127-5602  
405-946-1461  
800-351-9088  
Fax 405-946-1472  
smico@smico.com  
www.smico.com